



ICC Evaluation Service, Inc.
www.icc-es.org

Business/Regional Office ■ 5360 Workman Mill Road, Whittier, California 90601 ■ (562) 699-0543
Regional Office ■ 900 Montclair Road, Suite A, Birmingham, Alabama 35213 ■ (205) 599-9800
Regional Office ■ 4051 West Flossmoor Road, Country Club Hills, Illinois 60478 ■ (708) 799-2305

Legacy report on the BOCA® *National Building Code/1999*

DIVISION: 09—FINISHES

Section: 09260—Gypsum Board Assemblies

EVALUATION SUBJECT:

H-Stud Fire Wall/Party Wall

REPORT HOLDER:

National Gypsum Company
2001 Rexford Road
Charlotte, NC 28211

EVALUATION SCOPE

Compliance with the following code:

BOCA® *National Building Code/1999*

- Section 704.4.1.1 Elementary materials
- Section 704.1.1 Fireresistance rating
- Section 707.1 General-fire walls and party walls
- Section 2503.2 Standards

1.0 DESCRIPTION OF EVALUATION

Gold Bond® H-Stud Fire Wall/Party Wall has been evaluated for use as a fire wall, party wall and fire separation wall.

2.0 DESCRIPTION AND USE OF PRODUCT

H-Stud walls are non-load bearing wall assemblies of gypsum panels and steel studs designed for use as fire walls, party walls and fire separation walls having a fireresistance rating of 2 hours. See Figure 1. For further details of the 2 hour fireresistance rated assemblies see Section 4.2 and Section 4.3 of this report.

When constructing the H-Stud walls the following methods shall be used to separate the assembly from any adjacent framing members: Full sheets, battens or a 1" air space shall be installed between the assembly and adjacent solid construction, as required in the assembly when tested.

In addition, aluminum clips are incorporated into the assembly to act as a fusible link between the assembly and both sides of adjacent framing members. Aluminum angle clips, having a melting point of 1220° F, are used to attach the H-Stud to both sides of adjacent framing members. When the firewall is subjected to high temperatures the clips on one side of the assembly will melt and break away, allowing distortion of the framing members on the fire side without jeopardizing the performance of the fire wall itself.

The H-Stud Fire Wall/Party Wall assemblies, with full sheets of Gold Bond® Brand Fire-Shield G gypsum wallboard attached to either side, are acceptable for installation where floor-to-ceiling heights do not exceed 12'-11" and will withstand a transverse 5 psf load without exceeding 1/240 allowable deflection. When 1/2-inch strips of Gold Bond® Fire-Shield gypsum wallboard are utilized as battens, or a minimum 1" air separation is maintained, the H-Stud wall is suitable for installation where floor-to-ceiling heights do not exceed 11'-9" under a 5 psf transverse load without exceeding 1/240 allowable deflection.

An approved firestopping material (4 pcf minimum density) or gypsum board strips shall be used to firestop openings adjacent to the fire wall at floor and ceiling levels and at terminations with the roof deck or exterior walls. See Figures 2 and 3 for typical installation examples.

Fire wall projections through roof decks or exterior walls shall be covered by noncombustible flashing that will resist corrosion and galvanic action. The flashing shall be designed to have the ability to slip to allow for expansion or movement due to fire. See Figures 4 and 5 for typical installation examples.

Penetrations for doors, not exceeding 36" x 84", shall be protected by an opening having a fireresistance rating of at least 1 1/2 hour tested and installed in accordance with the code.

National Gypsum Company shall supply installation instructions that describe the safe and proper handling of the product, methods of installation, types of fasteners and required fastening schedule. The installation instructions shall provide the minimum installation requirements as stated in the test assembly described in Section 4.2.

3.0 CONDITIONS OF USE

This report is limited to the applications and products as stated in this report. The ICC-ES Subcommittee on National Codes intends that the report be used by the code official to determine that the report subject complies with the code requirements specifically addressed, provided that this product is installed in accordance with the following conditions:

- 3.1** In exterior wall construction employing studs, the wall shall extend through the stud space to the exterior sheathing.
- 3.2** Firestopping at intermediate floors shall comply with the provisions of Section 721.0 of the BOCA® *National Building Code/1999*.
- 3.3** Fireresistance rated walls shall be installed as described in Section 4.2 and 4.3 of this report.

ICC-ES legacy reports are not to be construed as representing aesthetics or any other attributes not specifically addressed, nor are they to be construed as an endorsement of the subject of the report or a recommendation for its use. There is no warranty by ICC Evaluation Service, Inc., express or implied, as to any finding or other matter in this report, or as to any product covered by the report.

- 3.4 National Gypsum Company shall supply installation instructions that describe the safe and proper handling of the product, methods of installation, types of fasteners and required fastening schedule. The installation instructions shall provide the minimum installation requirements as stated in the test assembly described in Sections 4.2 and 4.3 of this report.
- 3.5 A minimum 1" air space shall be established between the 2" H-Stud assembly and adjacent solid construction, as required in the assembly when tested and as illustrated in Figures 2a, 2b and 3.
- 3.6 Penetrations through the H Stud Firewall/Party wall shall be protected in accordance with the appropriate provisions of Section 707.10 of the BOCA® *National Building Code/1999*. In addition, penetrations shall not adversely effect the requirements of Section 707.1, which requires the H Stud Firewall/Party wall to have sufficient structural stability under fire conditions to allow the collapse of construction on either side without collapse of the firewall/party wall.
- 3.7 H Stud firewalls have not been evaluated for in plane and lateral loads (caused by wind or seismic conditions) or for use as an exterior wall.
- 3.8 The maximum height of the wall shall be 44 feet.
- 3.9 This report is subject to periodic re-examination. For information on the current status of this report, contact the ICC-ES.

4.0 INFORMATION SUBMITTED

- 4.1 H-Stud Fire Wall/Party Wall. CertainTeed Research and Development Laboratory Project No. 70002, dated March 4, 1986.

Gold Bond® Brand Gypsum Board met the criteria stated in Section 902.4.1.1 for a noncombustible material.

- 4.2 Warnock Hersey International, Fire Laboratories Division. Report No. WHI-651-0400.12 and WHI 651-0508, dated June 10, 1987, September 14, 1987 and February 3, 1992.

An assembly consisting of 2-inch H-Stud area separation wall with steel stud wall and floor/ceiling juncture on one side (not symmetrical) was tested in accordance with ASTM E119. Test exposure was in the direction of the area separation wall side.

Thermocouples were placed in contact with the wood studs on the face toward the fire side. This face was protected by the two layers of 1 inch Gold Bond® Brand Fire-Shield Shaftliner. Five thermocouples were symmetrically located on the wall section below the floor/ceiling section and two were on midpoint of wall section above the floor/ceiling section.

At the conclusion of the ASTM E119 test the thermocouples recorded a temperature rise of 166° F (250 is the limit) and the high individual temperature rise of 224° F (325 is the limit). The wall assembly withstood a 2-hour fire endurance test, without the passage of flames or hot gases which are hot enough to ignite cotton waste. The wall withstood the hose stream exposure which is required by the standard. The firewall has therefore been determined to be a 2 hour fire resistance rated fire wall.

- 4.3 Warnock Hersey International, Fire Laboratories Division, Report No. WHI-694-0200.6, dated October 21 and 24, 1985.

A symmetrical assembly consisting of 2 inch H Stud Area Separation Wall was tested in accordance with

ASTM E119. The test assembly consisted of 10 foot pieces of nominal 2-inch U channel attached to both the top and bottom of the frame with 1/4" Uni-strut bolts, spaced 24" o.c. Ten foot pieces of 1"x 2" "L" shaped runners were fastened to the sides of the frame with 1 1/2" masonry nails spaced 16" o.c. A double layer of 10 foot pieces of 1 inch shaftliner, friction fitted between 10 foot high, 2 inch H studs, were placed in the top and bottom U channels. The double layer of shaftliner was screwed to the L runner at the sides of the frame with 2 5/8" Type S screws, 12" o.c. Six inch wide strips of 1/2" thick Fire-Shield G type X gypsum wallboard were attached on both faces over the H stud using 1 5/8" long Type S screws. Three inch wide strips of 1/2 inch thick Fire-Shield G gypsum wallboard were attached around the perimeter of the assembly covering exposed metal of the L and U runners by using 1" Type S screws spaced 12" o.c.

Nine thermocouples were placed on the unexposed face of the assembly. One thermocouple was located at the centers of the quarter sections. Four were on the gypsum battens over the center line of the H-studs, two were at upper 1/3 points and two were located at the lower 1/3 points.

At the conclusion of the ASTM E119 test the thermocouples recorded an average temperature rise of 218° F (250° F is the limit). The results from the test concluded that the wall assembly withstood a 2 hour fire endurance test in addition to the hose stream test.

- 4.4 PFS Corporation Report Nos. 86-94 and 86-95, dated December 3, 1986 and November 22, 1986.

This test was performed by first attaching the test panel to the test frame with aluminum angle clips in order to test the fastening method used. There are two tests which are used for the material: a transverse load test, and the 24 hour transverse load test.

Both tests are accomplished by subjecting the panels to loads produced by air bags having full contact to one face of the panel. The panel is then loaded and unloaded and the data is recorded. The panel was able to withstand a pressure of 9.5 psf and a deflection of L/240.

H-Stud Fire Wall/Party Wall Assembly demonstrated no damage, the steel studs were intact and there was no structural damage. The 24 hour test also demonstrated the assembly to have no structural failure while being tested.

- 4.5 Pittsburgh Testing Laboratory, Reports Nos. 1-86-G1, 1-86-G2, and 1-86-G3, dated February 20, 1986.

Flexural strength, humidified deflection, core, end, and edge hardness, nail pull resistance, and dimensions and permissible variations tests were conducted in accordance with ASTM C473-84a. The 1/2" thick Fire-Shield G and 5/8" thick Fire-Shield met the standard specification requirements for gypsum wallboard in accordance with ASTM C36-85. The 1" thick Fire-Shield Shaftliner met the standard specification requirements for gypsum backing board and coreboard in accordance with ASTM C442-84a.

5.0 PRODUCT IDENTIFICATION

All one inch Gold Bond® Brand Shaftliner shall be marked at the plant with the identifying language "See ICC-ES Legacy Report No. 90-26." All Gold Bond® Brand 1/2" Fire Shield G type X and Fire-Shield G MR type X gypsum board shall be identified as such along one edge of the face of the board within the taper.

This report is subject to re-examination in one year.

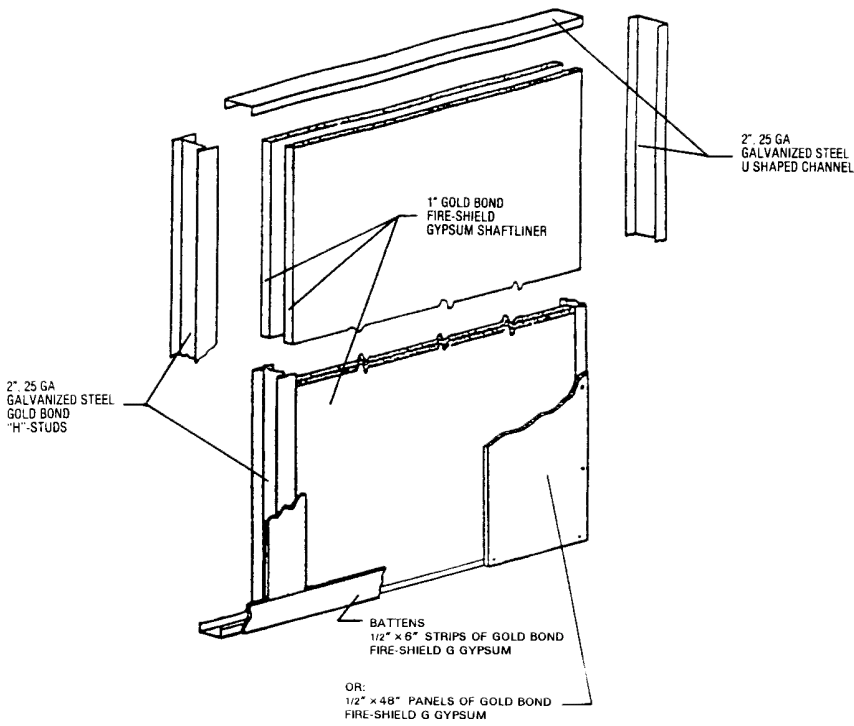

FIGURE 1*

BASIC COMPONENTS OF THE 2-HOUR FIRERESISTANCE RATED "H"-STUD FIRE WALL/PARTY WALL (Aluminum Clips Not Shown)

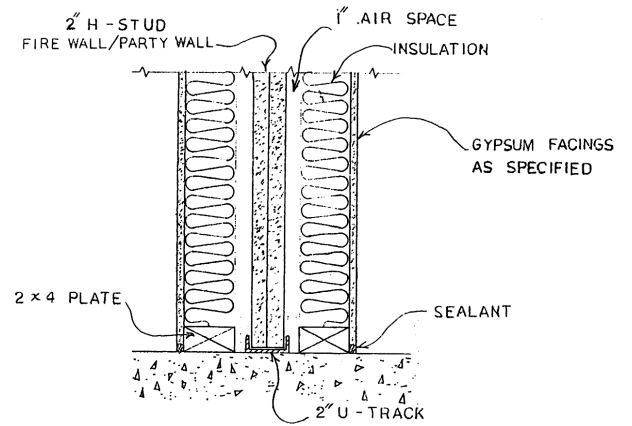

FIGURE 2a*

TYPICAL FOUNDATION DETAIL

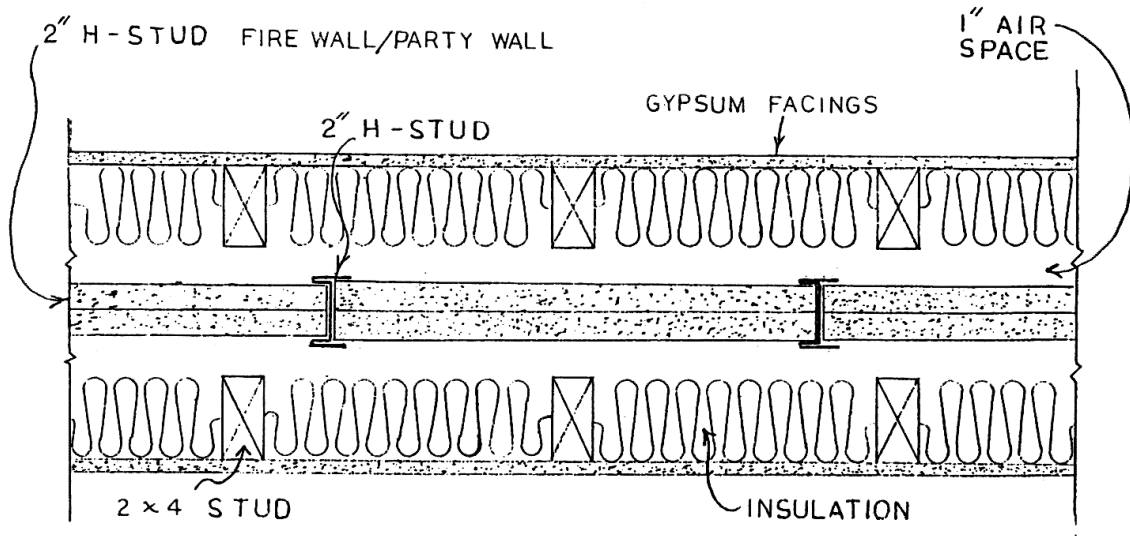

FIGURE 2b*

TYPICAL WALL CROSS SECTION

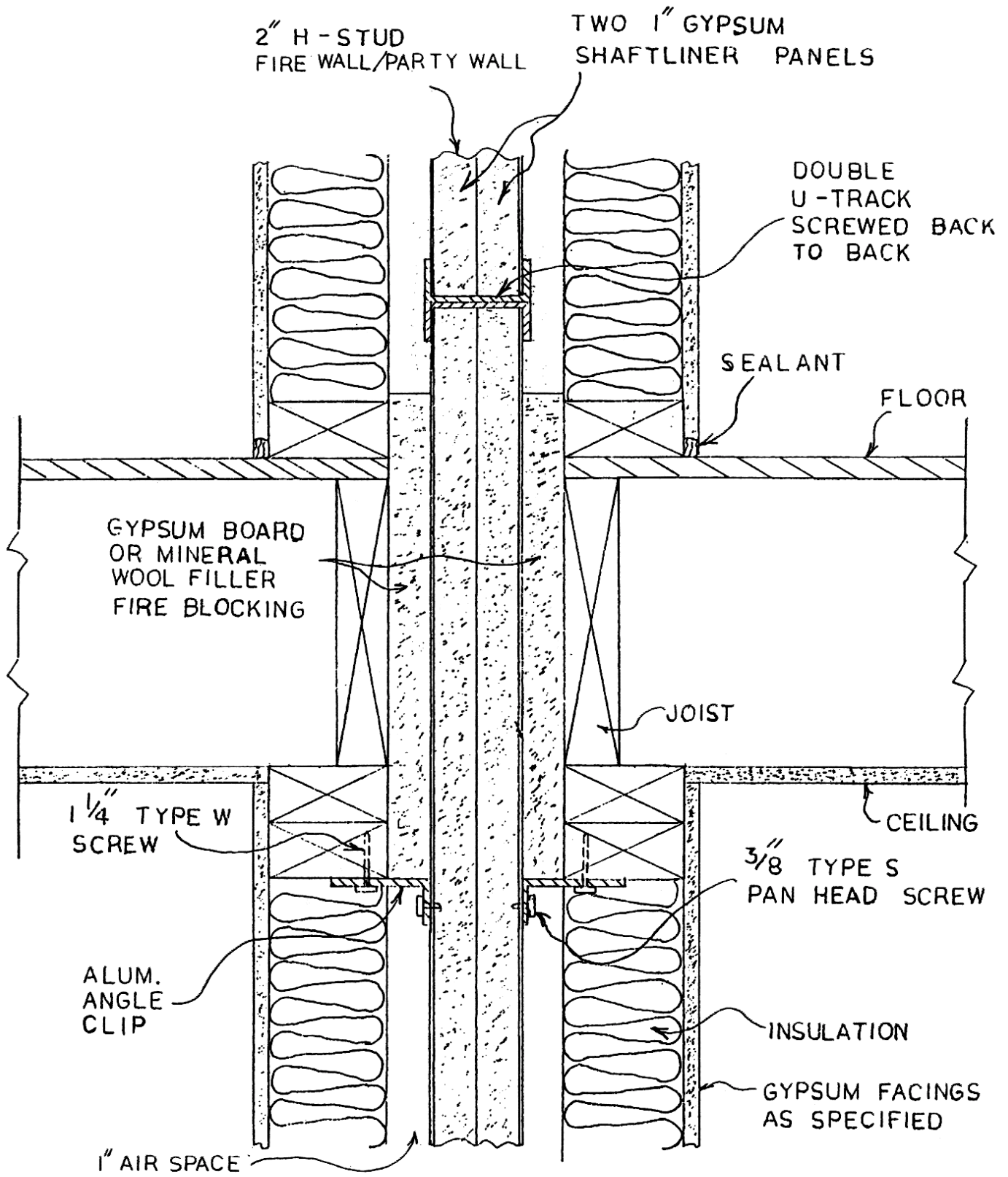

FIGURE 3*

INTERMEDIATE FLOOR INTERSECTION
LOCATION OF ALUM. ANGLE CLIPS

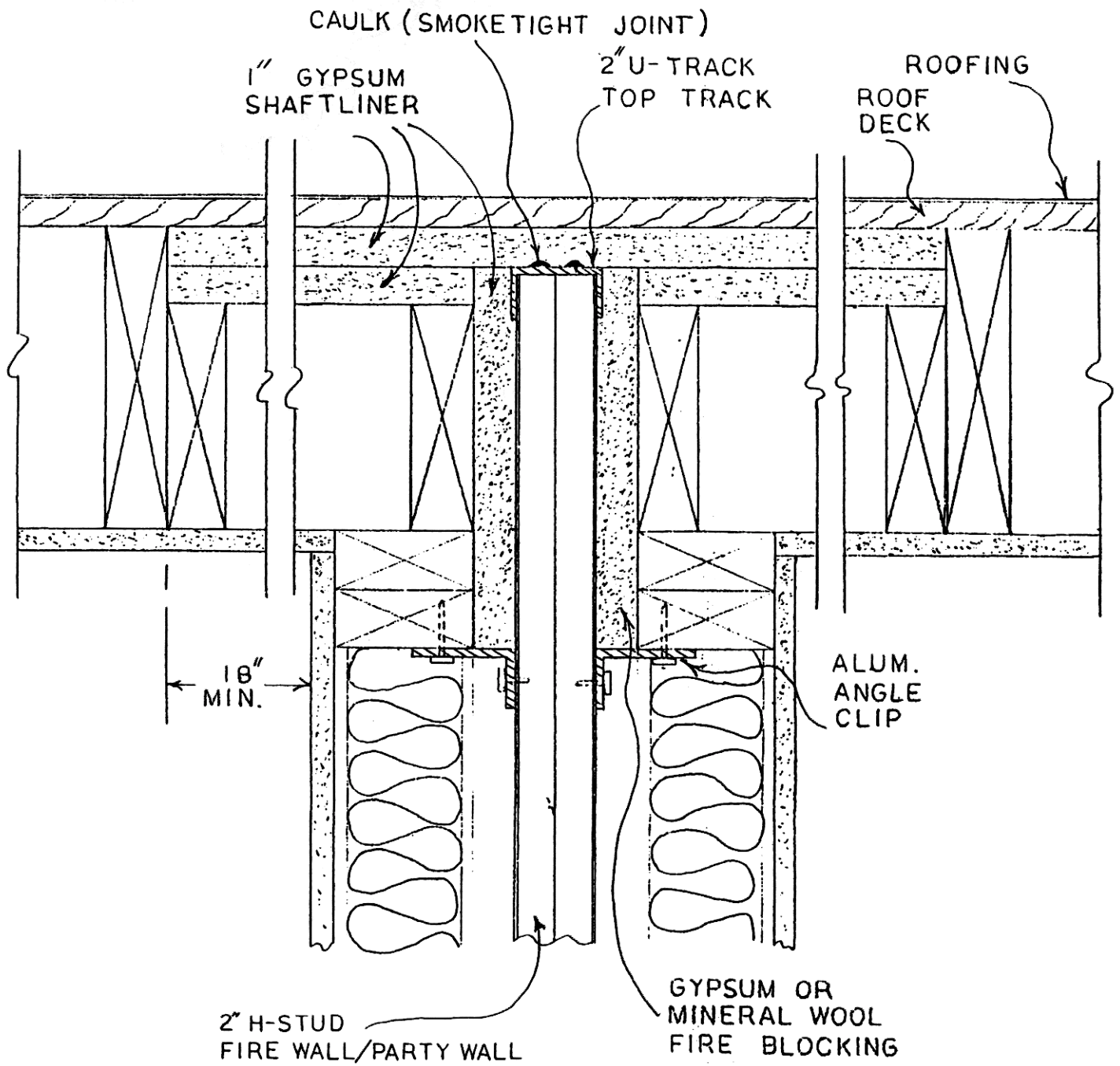

FIGURE 4*

TYPICAL ROOF JUNCTION DETAIL

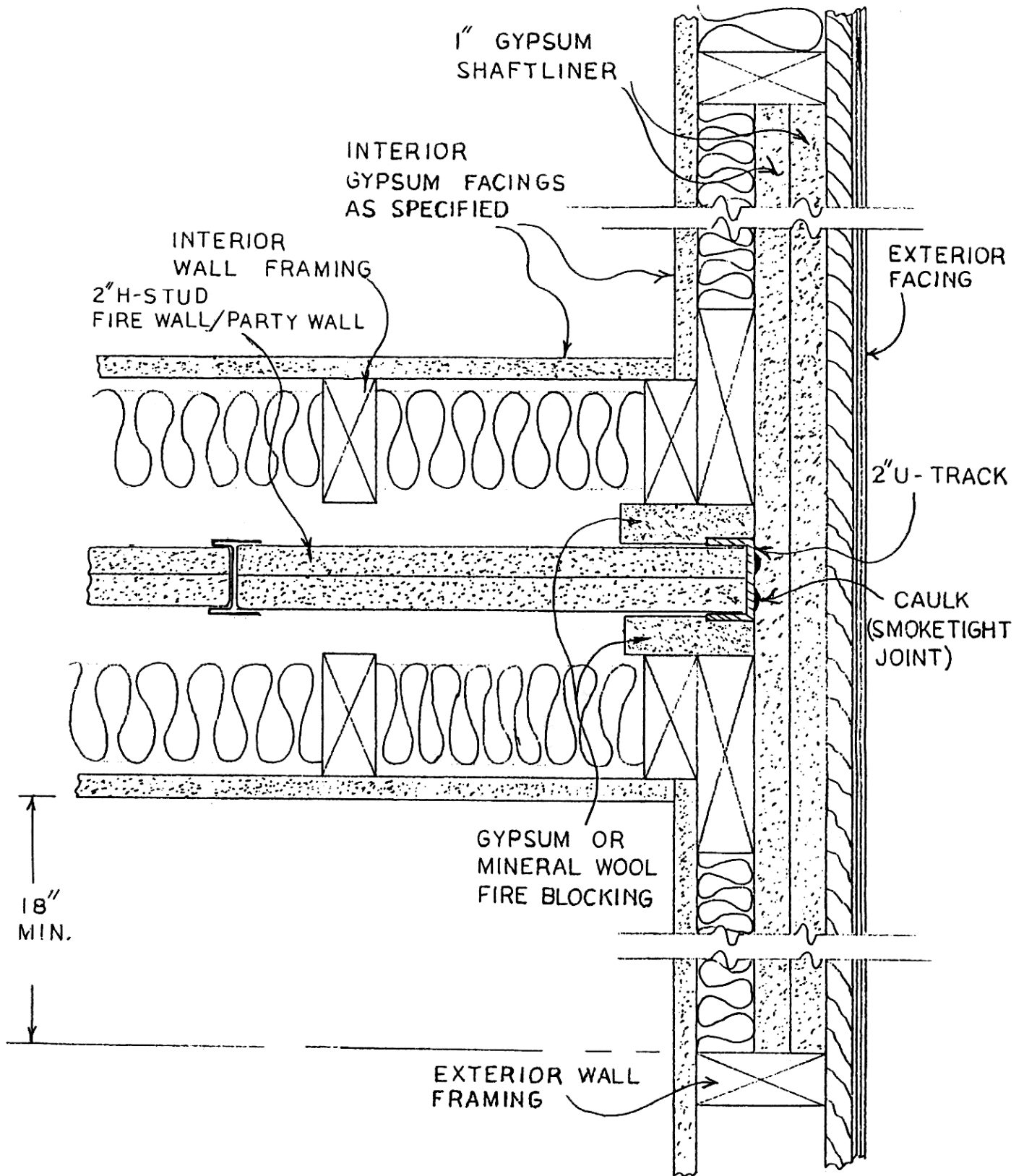

FIGURE 5*

EXTERIOR WALL INTERSECTION

*THESE DRAWINGS ARE FOR ILLUSTRATION PURPOSES ONLY. THEY ARE NOT INTENDED FOR USE AS CONSTRUCTION DOCUMENTS FOR THE PURPOSE OF FABRICATION OR ERECTION.